



# FINANCIAL PRESENTATION

October 2014

fuoco



aria



terra

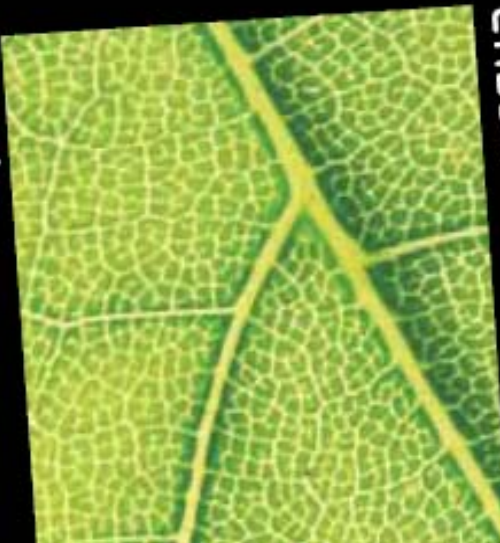

acqua



# Product range



Single ring burners



Special and multi rings burners



Gas valves



Micro switches  
& accessories



Oven hinges



Thermostats



Oven burner

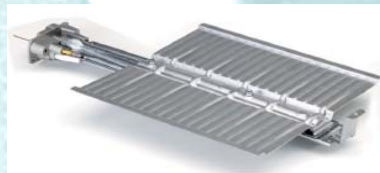

# Global presence

100% valves and thermostats  
100% hinges  
100% special burners  
50% standard burners



25% standard burners



special burners - starting 2015



25% standard burners

# Becoming more international

- Sabaf enjoys a strong leadership position in Italy and Europe (market share above 40%)
- Demographic and macroeconomic trends do not leave space for substantial growth in Europe
- Sabaf market share worldwide is still low (around 10%)
- Efforts are mainly addressed at increasing our international presence, with special focus on:
  - Turkey
  - China
  - Brazil
  - India

# Sabaf in Brazil

Sabaf production in Brazil started in 2001, in order to:

- be next to the customer in a major, growing market
- avoid duties
- avoid forex impacts

A new factory was set up in Jundiaí (SP) in 2007, starting from greenfield

Same products, technology and quality as in Italy

- € 10 mn investment - 5,000 sqm
- Manufacturing of standard burners for Latin American markets
- All production phase made locally and in-house
- € 4.0 mn sales in H1 2014, 90 people employed



# Sabaf in Turkey

Turkey has become the most important manufacturer of white goods in Europe (Turkish manufacturers and production sites of multinational groups)

In 2012 Sabaf built from greenfield a new factory in Manisa (Izmir)

Same products, technology and quality as in Italy



- € 10 mn investment - 10,000 sqm
- Manufacturing of standard burners
- € 4.6mn sales in H1 2014, 50 people employed
- Further expansion of production capacity is ongoing, constant growth has been planned for the following years

# Sabaf in China

- Market size: 26 mn hobs
  - 19 mn hobs manufactured for the domestic market
  - 7 mn hobs manufactured for export markets
- Expected product mix trend: higher value, moderate volume growth
- 92% of hobs consist of 2 burners and 2 valves
- Sabaf is targeting 10% premium market
  
- As for burners, we will start a fully owned factory by the beginning of 2015. Expected capex of € 2mn in 2014-2015. Manufacturing of DCC special burners
- As for valves, no decision has been made yet

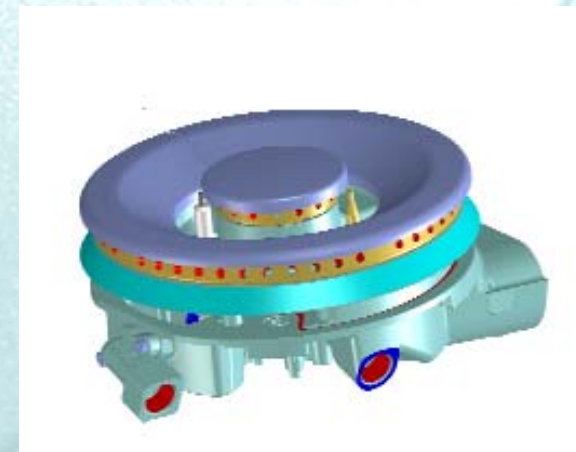

# Sales by market

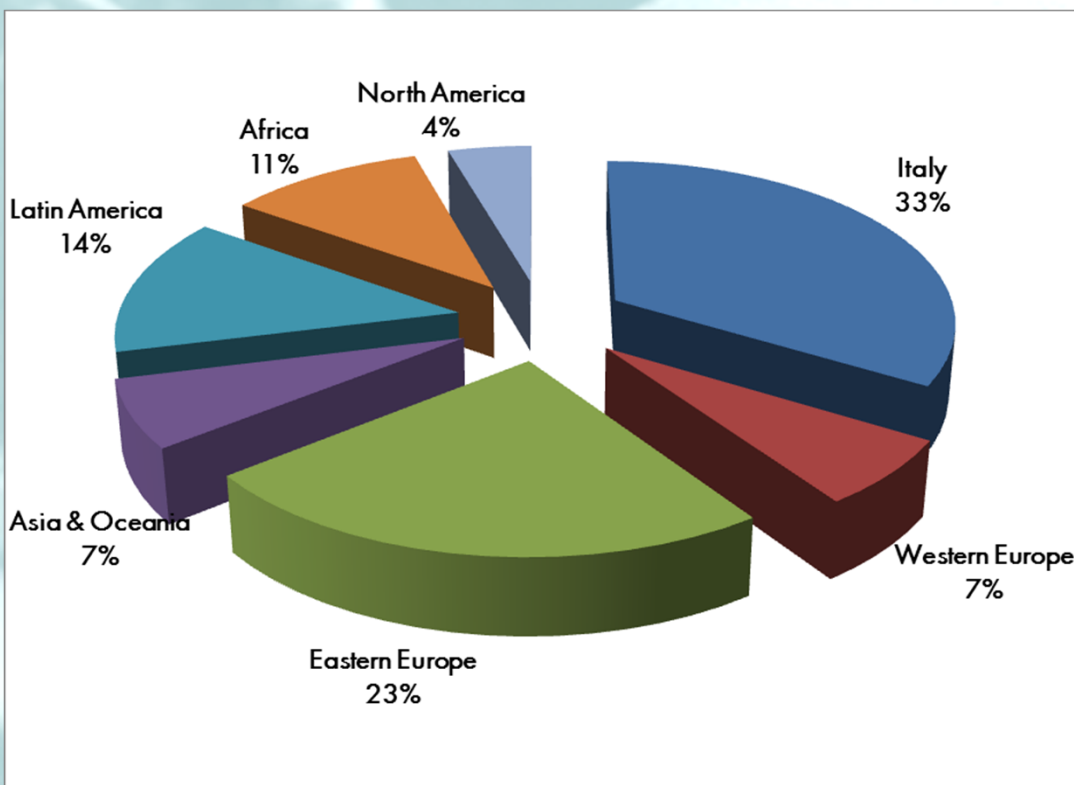

|                | H1 2014       | H1 2013       | Change       |
|----------------|---------------|---------------|--------------|
| Italy          | 23,971        | 24,353        | -1.6%        |
| Western Europe | 4,750         | 3,392         | +40.0%       |
| Eastern Europe | 17,188        | 15,015        | +14.5%       |
| Asia & Oceania | 4,795         | 6,206         | -22.7%       |
| Latin America  | 9,750         | 11,769        | -17.2%       |
| Africa         | 7,611         | 5,462         | +39.3%       |
| North America  | 3,220         | 2,204         | +46.1%       |
| <b>Total</b>   | <b>71,285</b> | <b>68,401</b> | <b>+4.2%</b> |



# Sales by product line

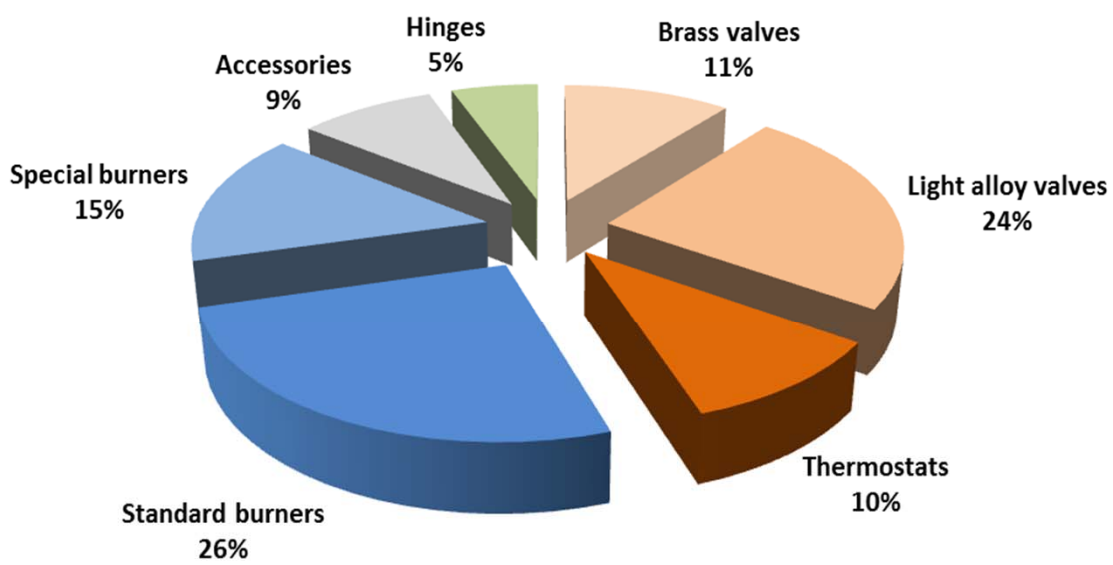

|                    | H1 2014       | H1 2013       | Change       |
|--------------------|---------------|---------------|--------------|
| Brass valves       | 7,692         | 7,950         | -3.2%        |
| Light alloy valves | 17,025        | 14,760        | +15.3%       |
| Thermostats        | 7,284         | 7,036         | +3.5%        |
| Standard burners   | 18,335        | 19,268        | -4.8%        |
| Special burners    | 10,695        | 9,957         | +7.4%        |
| Accessories        | 6,269         | 6,195         | +1.2%        |
| Hinges             | 3,985         | 3,235         | +23.2%       |
| <b>Total</b>       | <b>71,285</b> | <b>68,401</b> | <b>+4.2%</b> |

# New products - DCC burners range

- A range of 24 different products
  - ✓ 1 way / 2 ways
  - ✓ air from top / air from bottom
  - ✓ 3 different sizes
  - ✓ aluminium / brass ring / full brass
- A portfolio of products compliant with all standards in every country in the world
- The highest efficiency available on the market

# New products - DCC burners range



DCC HE 1way AFT



DCC HE Dual 2ways AFT



DCC HE Dual 2ways AFB

Ø 113 mm.

Ø 123 mm.

Ø 135 mm.



Small 3.5 kW.

Medium 4.0 kW.

Big 5.0 kW.



Ø 123 mm.

Ø 135 mm.



# New products - Lotus/S4 burners range

Consumers in SAARC countries ask for

- Products customized to their cooking habits
- Flame aspect and correct heat distribution are important features
- Easy assembly and traditional “looks like”
- High efficiency and low gas consumption.
- Poka-Yoke (mistake proofing) characteristics
- Resistance to dirt and to usage



# New products - Lotus/S4 burners range

## SABAF S4 burners

- satisfy end users cooking needs: European style product with Indian cooking requirements
- grant 70% efficiency on built-in hobs ,not been done on any other built-in hob till now.
- CO-CO2 emissions are half of what is currently on any other local brass burner
- Output ranges 1.7 KW-2,5 KW
- Sizes - Ø85 mm small - Ø100 mm medium
- Are available both for built-in hobs and cooktops



# Income statement



€ x 000

|                                   | Q2 14         |               | Q2 13         |               | H1 14         |               | H1 13         |               | FY 13         |               |                |               |
|-----------------------------------|---------------|---------------|---------------|---------------|---------------|---------------|---------------|---------------|---------------|---------------|----------------|---------------|
| <b>SALES</b>                      | <b>38,161</b> | <b>100.0%</b> | <b>37,028</b> | <b>100.0%</b> | <b>+3.1%</b>  | <b>71,285</b> | <b>100.0%</b> | <b>68,401</b> | <b>100.0%</b> | <b>+4.2%</b>  | <b>130,967</b> | <b>100.0%</b> |
| Materials                         | (15,291)      | -40.1%        | (16,284)      | -44.0%        |               | (29,637)      | -41.6%        | (29,968)      | -43.8%        |               | (52,415)       | -40.0%        |
| Payroll                           | (8,776)       | -23.0%        | (8,440)       | -22.8%        |               | (16,793)      | -23.6%        | (16,338)      | -23.9%        |               | (31,339)       | -23.9%        |
| Change in stock                   | 825           | 2.2%          | 3,109         | 8.4%          |               | 2,451         | 3.4%          | 6,005         | 8.8%          |               | 4,784          | 3.7%          |
| Other operating costs/income      | (6,969)       | -18.3%        | (7,765)       | -21.0%        |               | (13,349)      | -18.7%        | (14,752)      | -21.6%        |               | (27,425)       | -20.9%        |
| <b>EBITDA</b>                     | <b>7,950</b>  | <b>20.8%</b>  | <b>7,648</b>  | <b>20.7%</b>  | <b>+3.9%</b>  | <b>13,957</b> | <b>19.6%</b>  | <b>13,348</b> | <b>19.5%</b>  | <b>+4.6%</b>  | <b>24,572</b>  | <b>18.8%</b>  |
| Depreciation                      | (3,155)       | -8.3%         | (3,215)       | -8.7%         |               | (6,279)       | -8.8%         | (6,444)       | -9.4%         |               | (12,856)       | -9.8%         |
| Gains/losses on fixed assets      | 4             | 0.0%          | 0             | 0.0%          |               | 24            | 0.0%          | 0             | 0.0%          |               | 71             | 0.1%          |
| Impairment of fixed assets        | 0             | 0.0%          | (383)         | -1.0%         |               | 0             | 0.0%          | (383)         | -0.6%         |               | (655)          | -0.5%         |
| <b>EBIT</b>                       | <b>4,799</b>  | <b>12.6%</b>  | <b>4,050</b>  | <b>10.9%</b>  | <b>+18.5%</b> | <b>7,702</b>  | <b>10.8%</b>  | <b>6,521</b>  | <b>9.5%</b>   | <b>+18.1%</b> | <b>11,132</b>  | <b>8.5%</b>   |
| Net financial expense             | (145)         | -0.4%         | (180)         | -0.5%         |               | (265)         | -0.4%         | (339)         | -0.5%         |               | (637)          | -0.5%         |
| Foreign exchange gains/losses     | 32            | 0.1%          | (45)          | -0.1%         |               | 13            | 0.0%          | 39            | 0.1%          |               | (186)          | -0.1%         |
| Equity investments profits/losses | (149)         | -0.4%         | (151)         | -0.4%         |               | (264)         | -0.4%         | (289)         | -0.4%         |               | (498)          | -0.4%         |
| <b>EBT</b>                        | <b>4,537</b>  | <b>11.9%</b>  | <b>3,674</b>  | <b>9.9%</b>   | <b>+23.5%</b> | <b>7,186</b>  | <b>10.1%</b>  | <b>5,932</b>  | <b>8.7%</b>   | <b>+21.1%</b> | <b>9,811</b>   | <b>7.5%</b>   |
| Income taxes                      | (1,591)       | -4.2%         | (1,025)       | -2.8%         |               | (2,720)       | -3.8%         | (1,977)       | -2.9%         |               | (1,707)        | -1.3%         |
| Minorities                        | 0             |               | 0             |               |               | 0             |               | 0             |               |               | 0              |               |
| <b>NET INCOME</b>                 | <b>2,946</b>  | <b>7.7%</b>   | <b>2,649</b>  | <b>7.2%</b>   | <b>+11.2%</b> | <b>4,466</b>  | <b>6.3%</b>   | <b>3,955</b>  | <b>5.8%</b>   | <b>+12.9%</b> | <b>8,104</b>   | <b>6.2%</b>   |

# EBIT bridge H1 2013 - H1 2014

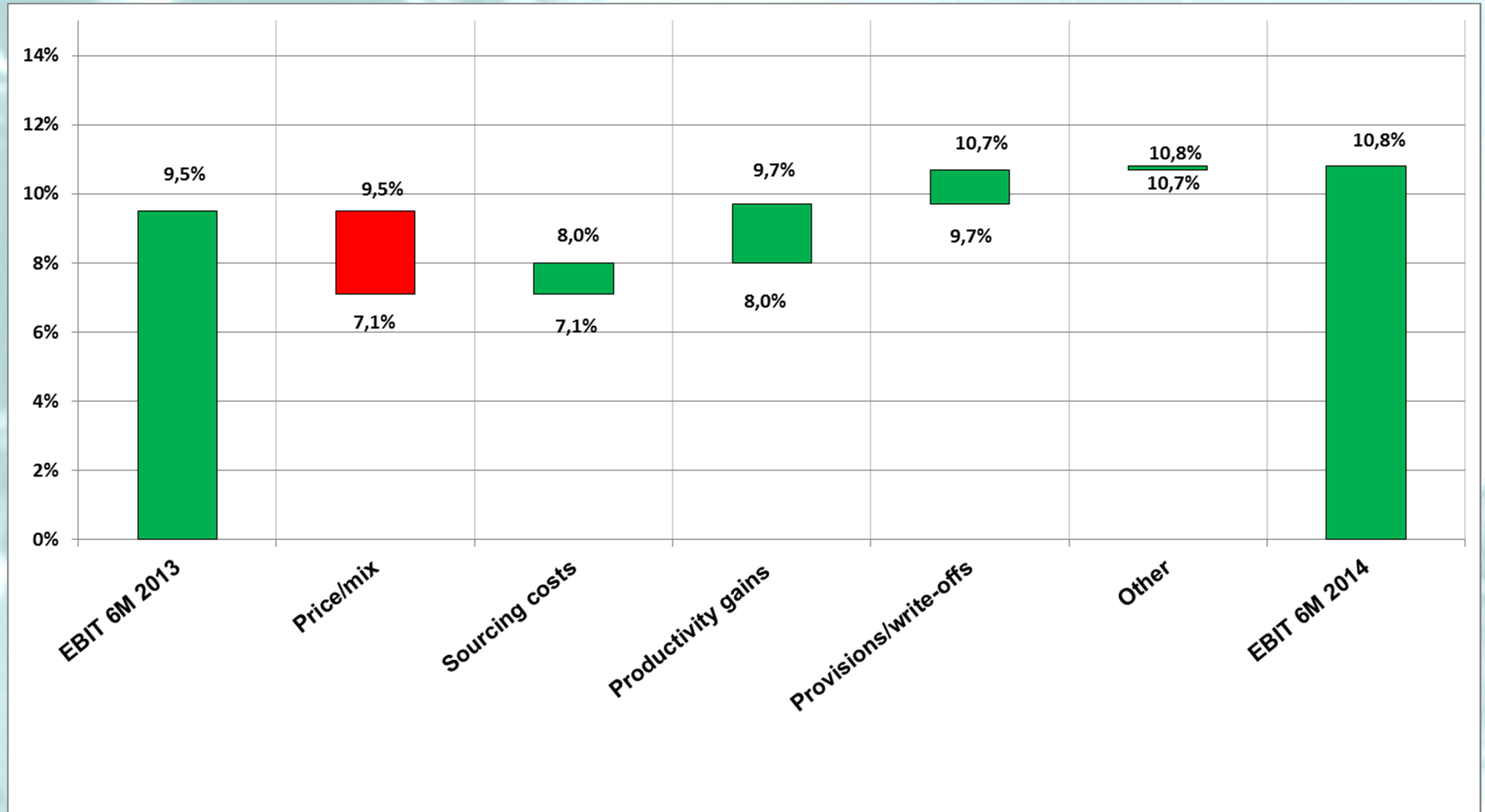

# Cash flow statement

| € x 1000                                   | H1 14          | H1 13          | FY 13          |
|--|----------------|----------------|----------------|
| <i>Cash at the beginning of the period</i> | 5,111          | 6,137          | 6,137          |
| Net profit                                 | 4,466          | 3,955          | 8,104          |
| Depreciation                               | 6,279          | 6,444          | 12,856         |
| Change in net working capital              |                |                |                |
| change in inventories                      | (10,115)       | (5,728)        | (4,190)        |
| change in receivables                      | (2,637)        | (5,968)        | 1,526          |
| change in payables                         | 5,857          | 6,150          | 419            |
|  | (6,895)        | (5,546)        | (2,245)        |
| Other changes in operating items           | 2,344          | 3,029          | 1,573          |
| <b>Operating cash flow</b>                 | <b>6,194</b>   | <b>7,882</b>   | <b>20,288</b>  |
| Investments, net of disposals              | (5,139)        | (4,338)        | (10,240)       |
| <b>Free cash flow</b>                      | <b>1,055</b>   | <b>3,544</b>   | <b>10,048</b>  |
| Cash flow from financial activity          | (4,144)        | (563)          | (8,118)        |
| Own shares sale (repurchase)               | 0              | (890)          | 3,084          |
| Dividends                                  | 0              | (3,911)        | (3,911)        |
| Forex                                      | 472            | (602)          | (2,129)        |
| <b>Net financial flow</b>                  | <b>(2,617)</b> | <b>(2,422)</b> | <b>(1,026)</b> |
| <i>Cash at the end of the period</i>       | <i>2,494</i>   | <i>3,715</i>   | <i>5,111</i>   |



# Balance sheet

| € x 1000  | 30-Jun-14      | 31-Dec-13      | 30-Jun-13      |
|---|----------------|----------------|----------------|
| Fixed assets  | 96,684         | 97,467         | 98,959         |
| Net working capital                                       | 45,950         | 41,241         | 43,742         |
| Short term financial assets                               | 5              | 22             | 11             |
| <b>Capital Employed</b>                                   | <b>142,639</b> | <b>138,730</b> | <b>142,712</b> |
| Equity  | 118,801        | 117,955        | 112,950        |
| Provisions for risks and<br>severance indemnity, deferred | 4,026          | 4,049          | 4,096          |
| Net debt  | 19,812         | 16,726         | 25,666         |
| <b>Sources of finance</b>                                 | <b>142,639</b> | <b>138,730</b> | <b>142,712</b> |
| Debt / Equity   | 0.17           | 0.14           | 0.23           |

# Net financial position

|           | € x 1000  | 30-Jun-14     | 31-Dec-13     | 30-Jun-13     |
|-----------|---|---------------|---------------|---------------|
| A.        | Cash  | 11            | 15            | 10            |
| B.        | Positive balances of unrestricted bank accounts | 2,010         | 4,519         | 2,528         |
| C.        | Other liquidities                               | 473           | 577           | 1,177         |
| D.        | Cash and cash equivalents (A+B+C)               | 2,494         | 5,111         | 3,715         |
| E.        | Current bank overdrafts                         | 17,885        | 15,503        | 22,484        |
| F.        | Current portion of non-current debt             | 1,055         | 1,363         | 2,466         |
| G.        | Other current financial payables                | -             | 1,076         | 11            |
| H.        | Current financial debt (E+F+G)                  | 18,940        | 17,942        | 24,961        |
| <b>I.</b> | <b>Current net financial debt (H-D)</b>         | <b>16,446</b> | <b>12,831</b> | <b>21,246</b> |
| J.        | Non-current bank payables                       | 1,398         | 1,859         | 2,316         |
| K.        | Other non-current financial payables            | 1,968         | 2,036         | 2,104         |
| L.        | Non-current financial debt (J+K)                | 3,366         | 3,895         | 4,420         |
| <b>M.</b> | <b>Net financial debt (L+I)</b>                 | <b>19,812</b> | <b>16,726</b> | <b>25,666</b> |

# Extraordinary dividend

- Payment of an extraordinary dividend of €1.00 per share -subject to the shareholders' approval on 28 October
- Rebalance of the financial structure

| Debt / Equity <sup>(1)</sup> |       | Debt / EBITDA <sup>(2)</sup> |       |
|------------------------------|-------|------------------------------|-------|
| before                       | after | before                       | after |
| 0.17                         | 0.26  | 0.81                         | 1.28  |

(1) based on figures at 30 June 2014

(2) based on Net debt at 30 June 2014 and 2013 EBITDA

- Prospects for constant cash flow generation
- Possibility of funding at very low interest rates
- No change in the implementation of the planned investment programmes
- Dividend yield at around 8%
- Dividend ex-date will be 10 November, with payment from 12 November 2014

# Forecasts

- For FY 2014, the Group confirms its forecasts of moderate growth in sales and profitability compared to 2013.
- These targets assume a macroeconomic scenario not affected by unpredictable events. If the economic situation were to change significantly, actual figures might diverge from forecasts.

# Stock price and main shareholders

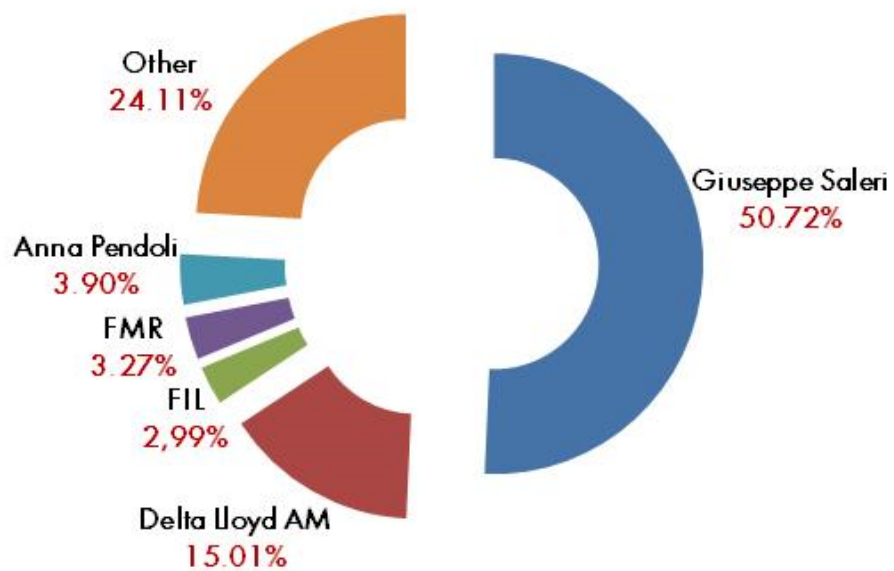
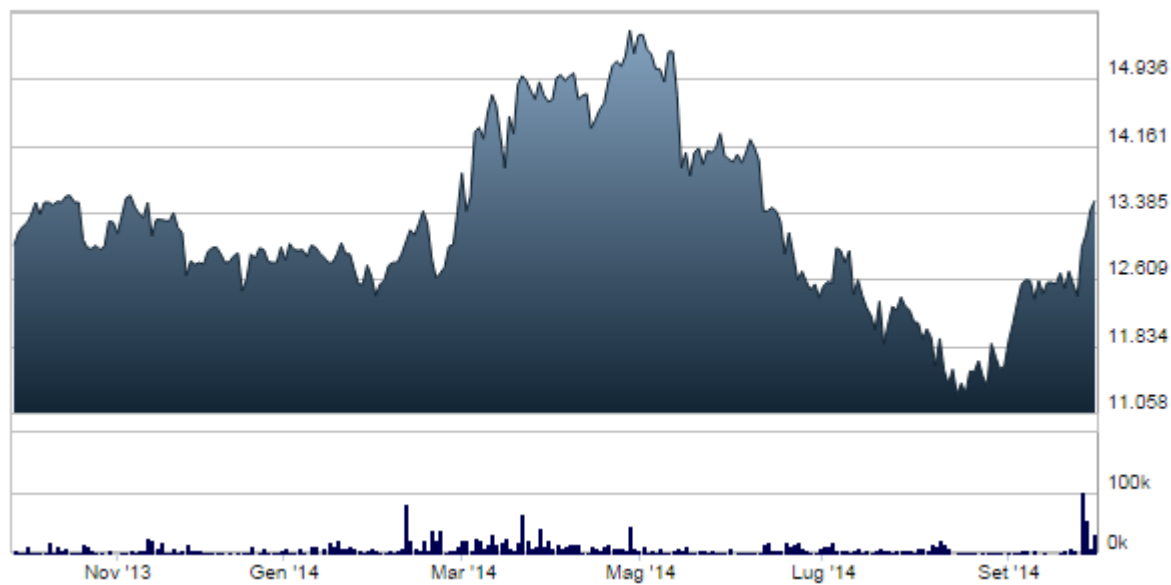

# Disclaimer

Certain information included in this document is forward looking and is subject to important risks and uncertainties that could cause actual results to differ materially.

The Company's business is in the domestic appliance industry, with special reference to the gas cooking sector, and its outlook is predominantly based on its interpretation of what it considers to be the key economic factors affecting this business. Forward-looking statements with regard to the Group's business involve a number of important factors that are subject to change, including: the many interrelated factors that affect consumer confidence and worldwide demand for durable goods; general economic conditions in the Group's markets; actions of competitors; commodity prices; interest rates and currency exchange rates; political and civil unrest; and other risks and uncertainties.

Pursuant to Article 154/2, paragraph 2 of the Italian Consolidated Finance Act (Testo Unico della Finanza), the company's Financial Reporting Officer Gianluca Beschi declares that the financial disclosure contained in this financial presentation corresponds to the company's records, books and accounting entries.

For further information, please contact

**Gianluca Beschi** - +39.030.6843236

[gianluca.beschi@sabaf.it](mailto:gianluca.beschi@sabaf.it)